



KAESER FILTER

KF F6 to F320 Series

Clean compressed air at low cost

Flow rate 0.6 to 32.0 m³/min, Pressure 2 to 16 bar

Clean compressed air at low cost

KAESER FILTER products are the key components for supplying compressed air of all purity classes as per the ISO 8573-1 standard and they achieve this with exceptionally low differential pressure.

Furthermore, their service-friendly design not only allows simple, error-free opening and closing of the filter housing, but also enables quick and clean element changes. **KAESER FILTER** products are available in four filter grades. A choice of twelve housing sizes provides efficient filtration for flow rates from 0.6 to 32.0 m³/min.

Standard-compliant purity

The **KAESER FILTER** range uses modern deep-pleated filter media to remove particles and aerosols, whilst highly effective carbon matting traps oil vapours. Together with innovative flow dynamics, they deliver exceptional filtration efficiency with minimal pressure loss. The impressive performance data of **KAESER FILTER** products have been determined in accordance with ISO 12500 and confirmed by the independent “Lloyd’s Register” testing agency.

Service-friendly design, straightforward handling

KAESER FILTER products feature a corrosion-resistant aluminium housing and stable filter elements. The practical bayonet lock ensures automatic positioning of the housing and element seals. Both seals are components of the filter element, which means that the filter housing can be sealed only if a filter element has been inserted. A locking screw provides venting for the housing and prevents unintentional opening whilst under pressure.

Minimal pressure loss, maximum savings

The efficiency of a compressed air filter depends most of all on pressure loss. **KAESER FILTER** products feature generously-sized housings and filter surfaces, innovative flow dynamics and high-performance filter media. These features result in up to 50% lower pressure loss in comparison to other filters on the market – a value that remains virtually constant throughout the entire service life of the filter element. This reduces the load on upstream compressors, thereby creating the potential for significant reductions in costs and CO₂ emissions.

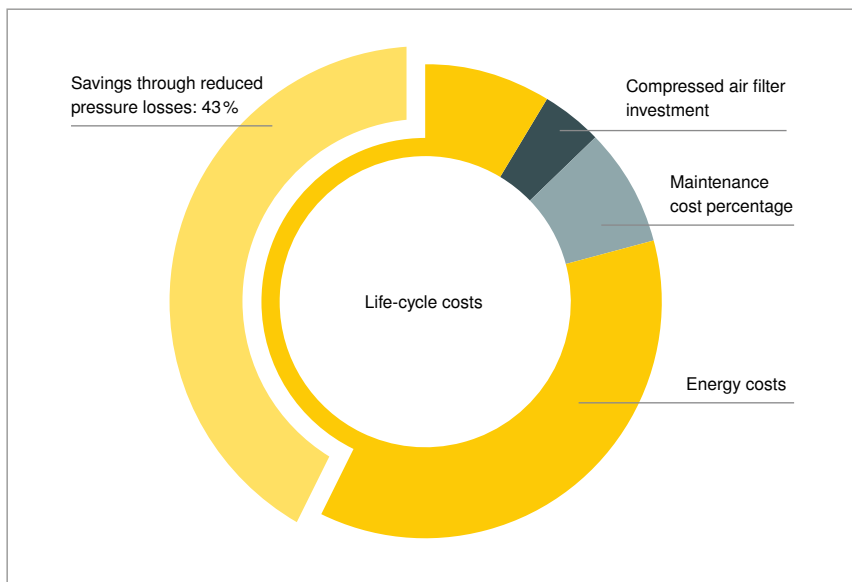

Coalescence filter example

- Flow rate 17.7 m³/min
- 50% lower pressure loss
- 6.55 kW/(m³/min)
- Additional energy requirement 6% per bar
- Cost of power: €0.2/kWh
- 8760 operating hours p.a.
- Annual debt service over 10 years



- (1) Compressed air inlet
- (2) Element head with housing and element seal
- (3) Filter element
- (4) Condensate outlet (here with automatic condensate drain)
- (5) Compressed air outlet
- (6) Locking screw
- (7) Bayonet lock with limit stop
- (8) Vent hole

Image: Functional diagram, coalescence filter



KAESER

KAESER FILTER products are available in four high-performance filter grades and can easily be connected to create filter combinations.

When used in combination with compressed air dryers and air-main charging systems from KAESER, they ensure dependable and energy-efficient compressed air treatment wherever and whenever it is needed.

Low differential pressure for maximum efficiency

Every bar of pressure loss increases energy costs by 6% per m³/min of compressed air. This general rule of thumb demonstrates that generously-sized KAESER FILTER products pay for themselves quickly.

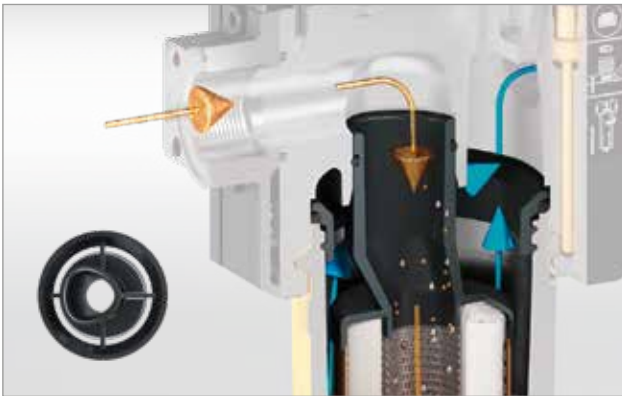

Large flow cross-section

KAESER FILTER products use filter elements with flow-optimised element heads. The filter inlet is offset towards the air inlet. This increases the flow cross-section at the air discharge side and further contributes to outstanding filter efficiency with minimal pressure loss.



Large connection sizes

Generously-dimensioned air connections on KAESER FILTER products help keep pressure losses to a minimum. Since KAESER FILTER products are available with various connection sizes, there is no need for reducer sections when connecting to different air distribution networks.

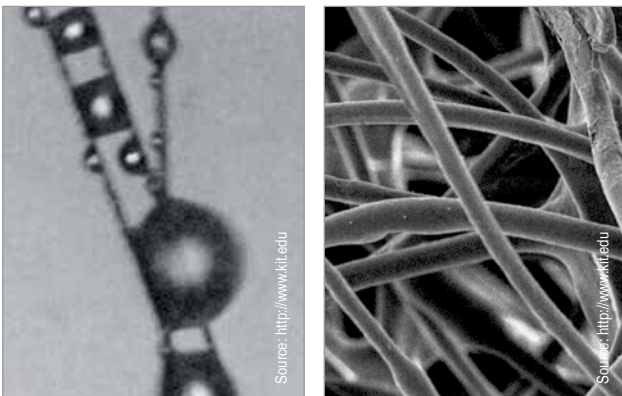

Low flow resistance

The polyester material used in the filter drainage layer ensures rapid oil drainage (left). Moreover, to achieve optimum filtration and contaminant retention with minimal pressure loss, KAESER particulate and coalescence filters feature high void volume filter media (right).

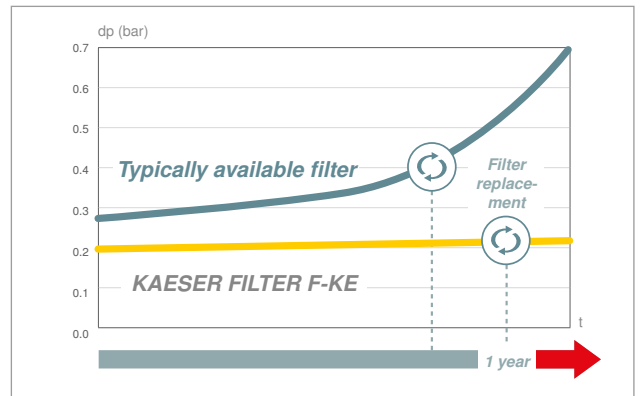

High contaminant retention capacity

KAESER FILTER products show a far lower pressure loss right from the outset compared to other typically available filters on the market. Moreover, the pressure loss remains low for much longer, thanks to the high contaminant retention capacity. The result: low operating costs over the long term. The annual maintenance of particulate and coalescence filters mitigates age-related risks and ensures maximum compressed air purity.

Standard-compliant purity in every quality class

Generously-dimensioned KAESER FILTER products have proven themselves in the most sophisticated of testing environments and in stringent measurement programmes. They provide exceptional reliability and efficiency – and are certified to affirm so.



Optimum flow distribution

The element head of KAESER FILTER units is optimised for best possible air flow. Its tapered internal structure channels the compressed air towards the centre of the element interior for even charging of the filter media. The result: high filtration efficiency with minimal pressure loss.

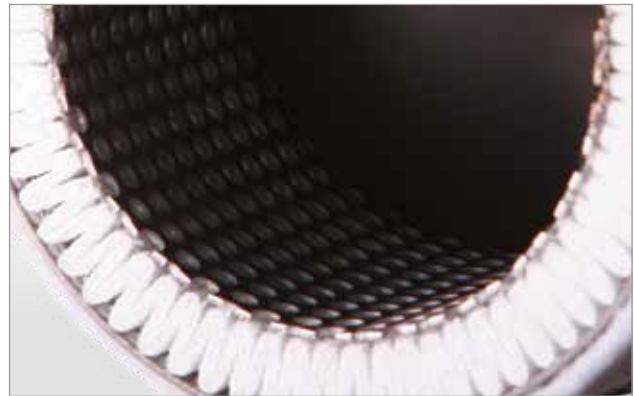

Deep-pleated filter elements

The deep-pleated KAESER particulate and coalescence filter elements feature exceptionally large filter surfaces. Through the resulting increase in efficiency, operating costs are significantly reduced compared to conventional filter designs.

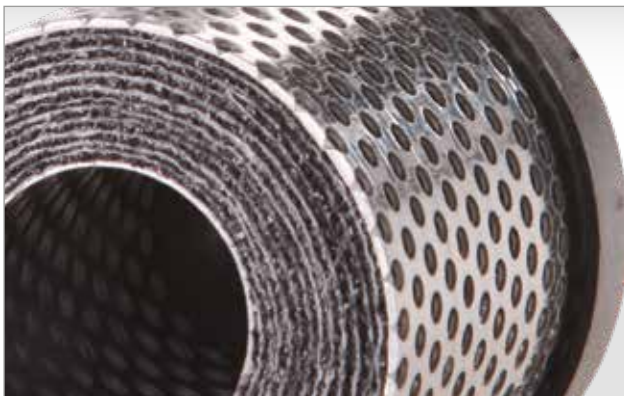

High-efficiency carbon matting

Unlike conventional filters, KAESER activated carbon filters with high-efficiency carbon matting prevent channelling whilst also ensuring reduced differential pressure. Moreover, the matting provides highly effective protection against particle release.



Application-tailored combinations

KAESER FILTER products can be combined flexibly at the user-end with optional connection kits. For example, the “Carbon Combination” – consisting of a KE coalescence filter (left) and a KA activated carbon filter (right) – not only retains aerosols and particulate matter, but also oil vapours.



Image: Selection from the filter element range

Degree of filtration	KB Coalescence filter Basic	KE Coalescence filter Extra	KD Particulate filter Dust	KA Activated carbon filter Adsorption	KBE Extra Combination	KEA Carbon Combination
Initial differential pressure at saturation	< 140 mbar	< 200 mbar	< 30 mbar (New, dry)	< 40 mbar (New, dry)	< 200 mbar	< 240 mbar
Aerosol content at inlet	10 mg/m ³	10 mg/m ³	–	–	10 mg/m ³	10 mg/m ³
Residual aerosol content at outlet as per ISO 12500-1 ¹⁾	< 0.1 mg/m ³	< 0.01 mg/m ³	–	–	< 0.01 mg/m ³	0.003 mg/m ³ (Total oil content)
Filter medium	Deep-pleated with support structure and polyester drainage matting		Deep-pleated with support structure	High-efficiency carbon matting	–	–
Application	Filtration of solid and liquid aerosols and solid particles	Same application as KB, but for higher compressed air quality Alternatively: Microparticle filter to KD degree of filtration	Exclusively for filtration of solid particles	Exclusively for removal of oil vapours	Combination of KB and KE; application as KE, but for higher compressed air quality	Combination of KE and KA, filtration of aerosols, solid particles and oil vapours

¹⁾ as per ISO 12500-1:06-2007



Image: Coalescence filter with ECO-DRAIN 31 F

Safe handling, service-friendly design

KAESER understands customers' needs, since the company itself operates numerous compressed air stations. From first-hand experience, we are well-versed in all aspects of compressed air station planning, commissioning, operation and maintenance. We draw on this expertise to create user-friendly and low-maintenance products.



Easy element change

KAESER FILTER units can be opened easily by hand. Servicing is a quick and almost completely clean process. The filter element can simply be unscrewed once the filter housing with element is released from the head. Minimal installation space is required beneath the filter.

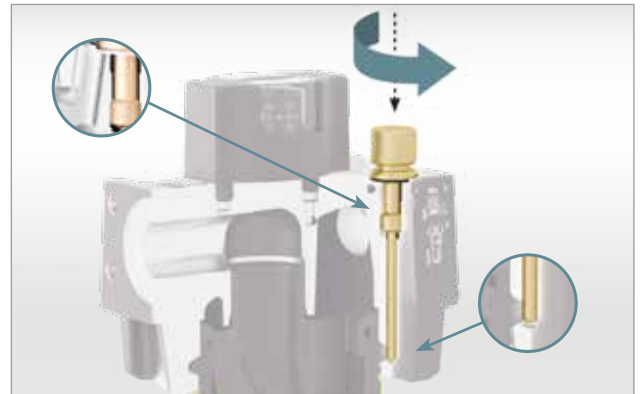

Safe opening

A locking screw protects the filter housing from unintentional opening. If released, a seal is broken and a vent hole is uncovered. If pressure is present, the user hears the warning sound of escaping air.



Typical design: Corrosion



KAESER: Zero corrosion

Corrosion-protected aluminium housing

The housings of KAESER FILTER products are cast from seawater-resistant aluminium. Several hundred hours of salt spray testing demonstrate their outstanding corrosion resistance.



Expanded metal mesh



KAESER: Robust profiled metal

Robust stainless steel cage

KAESER filter elements are protected by inner and outer cages made from continuously welded profiled stainless steel. These cages are far more resistant to mechanical stress than those made from simple expanded metal.

KAESER FILTER

To ensure that low energy costs and the required compressed air purity level are consistently maintained, the filter elements should be replaced at the end of their stipulated service life. Dependable aerosol filtration also requires dependable condensate drainage. The **ECO-DRAIN 31 F** Vario automatic condensate drain was especially designed for use with coalescence filters. Accumulating condensate is reliably removed with zero pressure loss.

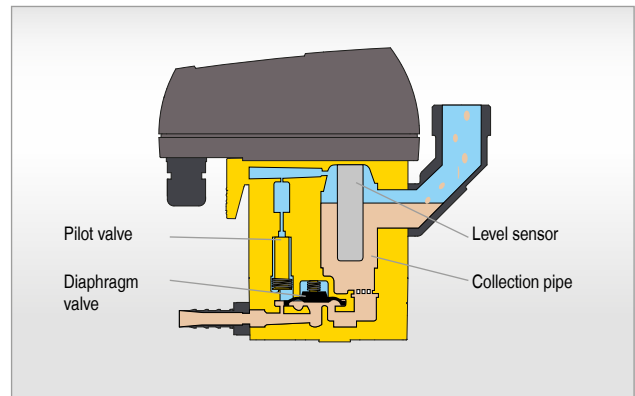
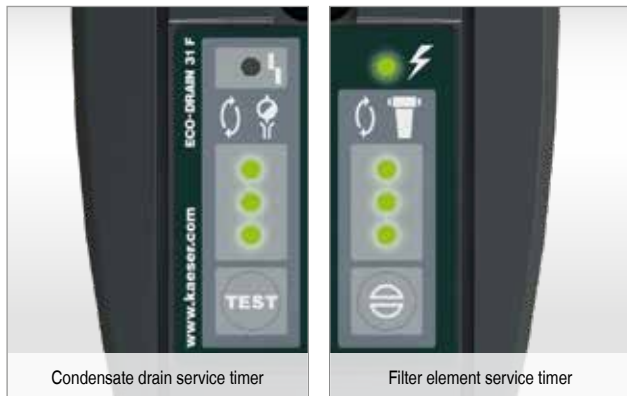

Service life monitoring

The ECO-DRAIN 31 F condensate drain not only monitors its own service interval but also that of the connected compressed air filter element. Service interval status is indicated via LEDs and a floating warning contact.

Dependable and loss-free

With contact-free sensing, ECO-DRAIN condensate drains detect the fill level and drain the condensate away, with zero pressure loss, via a pilot-controlled diaphragm valve. The large flow cross-sections eliminate the need for maintenance-intensive strainers.

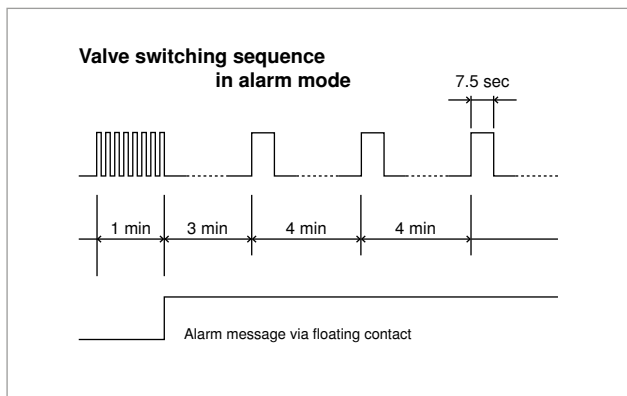

Self-monitoring

Should an issue with condensate drainage occur, the ECO-DRAIN valve opens at short intervals for one minute. If the condensate does not drain, a message is triggered and the valve opens every 4 minutes for 7.5 seconds. Once the condensate drains, the ECO-DRAIN reverts to normal operation.

Checked for leaks and proper function

All wearing components of the ECO-DRAIN 31 F can be exchanged with the service unit replacement without the need to change the seal. For trouble-free maintenance, the condensate drain and service unit are 100% factory-tested for leaks and proper function before leaving the plant.



Image: Coalescence filter with ECO-DRAIN 31 F

Degree of filtration	ECO-DRAIN 31 F	ECO-DRAIN 30	Automatic condensate drain	Manual condensate drain	Mechanical differential pressure gauge	Differential pressure transducer
KE	Up to F142	Selectable	Selectable	Selectable	Selectable (for use as microparticle filter downstream from KD degree of filtration)	Selectable
	From F184	Selectable	–	–		
KB	Up to F142	Selectable	Selectable	Selectable	–	Selectable
	From F184	Selectable	–	–		
KD	Up to F142	–	–	–	Standard	Selectable
	From F184					
KA	Up to F142	–	–	–	Standard	–
	From F184					

Optimum air quality for your applications





Consistently high efficiency

Fitted as standard to KAESER particulate and coalescence filters, the differential pressure gauge enables the operator to monitor pressure losses (i.e. efficiency) at a glance. Unlike other systems commonly available on the market, the contaminated and clean air sides are isolated from one another.

Equipment



Coalescence filter with ECO-DRAIN 31 F

Corrosion-protected, coated aluminium housing (configurable nominal widths); locking screw; differential pressure gauge and swivel ball valve (components fully assembled); KB or KE filter element and ECO-DRAIN 31 F electronic condensate drain with maintenance management (included).



Coalescence filter with ECO-DRAIN 30

Corrosion-protected, coated aluminium housing (configurable nominal widths); locking screw; differential pressure gauge and swivel ball valve (components fully assembled); KB or KE filter element and ECO-DRAIN 30 electronic condensate drain (included); up to model F142.



Coalescence filter with automatic condensate drain

Corrosion-protected, coated aluminium housing (configurable nominal widths); locking screw; differential pressure gauge and automatic condensate drain (components fully assembled); KB or KE filter element (included); up to model F142.



Particulate filter

Corrosion-protected, coated aluminium housing (configurable nominal widths); locking screw; differential pressure gauge and manual condensate drain (components fully assembled); KD or KE filter element (included).



Activated carbon filter

Corrosion-protected, coated aluminium housing (configurable nominal widths); locking screw; manual condensate drain (components fully assembled); KA filter element (included).



ECO-DRAIN 30

Ensures exceptionally safe, reliable condensate drainage without compressed air loss – even under conditions with widely fluctuating condensate accumulation and high particulate/oil content; simple function monitoring at the touch of a button; service unit 100% factory-tested for easy, trouble-free maintenance.



ECO-DRAIN 31 F

For use with aerosol filters; ensures safe and reliable condensate drainage without compressed air loss; maintenance management system displays elapsed replacement interval for the filter element and service unit (via LED); message for elapsed maintenance intervals provided via floating service contact; additional floating contact to relay alarm; function test button.

Additional options



Various connection sizes

Various nominal connection widths are available within each size range of KAESER FILTER products. There is a choice of BSP and NPT threaded connections. KAESER FILTER products can therefore be adapted to the user-end pipe distribution network with no need for reducer sections.



Differential pressure transducer

Instead of the mechanical differential pressure gauge, KAESER FILTER products can be equipped with an optional differential pressure transducer (factory-fitted). Along with the differential pressure, the three-wire sensor transmits the air-main pressure downstream from the filter as a 4-20 mA signal. Both values can then be passed on to master control systems such as the SIGMA AIR MANAGER 4.0 and from there can also be transmitted to the SIGMA NETWORK.

Accessories



Flange adapter DN 80 / 3 FLG

For 3-inch connections, PN16 nominal pressure rating flange adapters (DN80/3 FLG) are available as accessories from model F184 upwards. In the DIN version, they correspond to the DIN EN 1092-1 standard. In the ASME version they meet the criteria as per ANSI B16.5 – Class 150. The flange adapters feature a high-quality anti-corrosion coating and finish.



Wall-mount kit

Perfectly fitted and stable wall-mount brackets are available as an optional accessory for KAESER FILTER units, attaching easily to the connection flanges. The kit permits mounting of filter combinations comprising up to three filters. The installation tool required for attachment to the filter head is included.



Silicone-free version

KAESER FILTER products also include optional silicone-free versions that are compliant with test standard PV-VW 3.10.7. Each filter undergoes an individual coating test to confirm compliance. The supplied manufacturer's certificate attests that the product is silicone-free. Moreover, all filter elements for KAESER FILTER products are manufactured silicone-free in accordance with this regulation as standard.



Connection kit

Several KAESER FILTER units can easily be combined at the user-end with the optional connection kit. It contains the required screws, a gasket and the assembly tool.

Dimensions

Model F6 to F320

Model	A	B	C	D	E	F	G	H
	G	mm	mm	mm	mm	mm	mm	mm
F6	$\frac{3}{4}$ ($\frac{1}{2}$, $\frac{3}{8}$)	274	296	231	121	91	90	≥ 40
F9								
F16	1 ($\frac{3}{4}$)	305	327	259	132	102	100	≥ 40
F22		355	377	309				
F26		355	377	309				
F46	2 ($1\frac{1}{2}$, $1\frac{1}{4}$)	375	398	312	198	153	130	≥ 50
F83		460	483	397				
F110		660	683	597				
F142		660	683	597				
F184	3 (2, $2\frac{1}{2}$)	715	738	643	242	196	150	≥ 50
F250		843	866	771				
F320		985	1008	913				

G compressed air connections as per ISO 228, optional NPT connections as per ANSI B 1.20.1.

Views

Models shown: F16/F22/F26

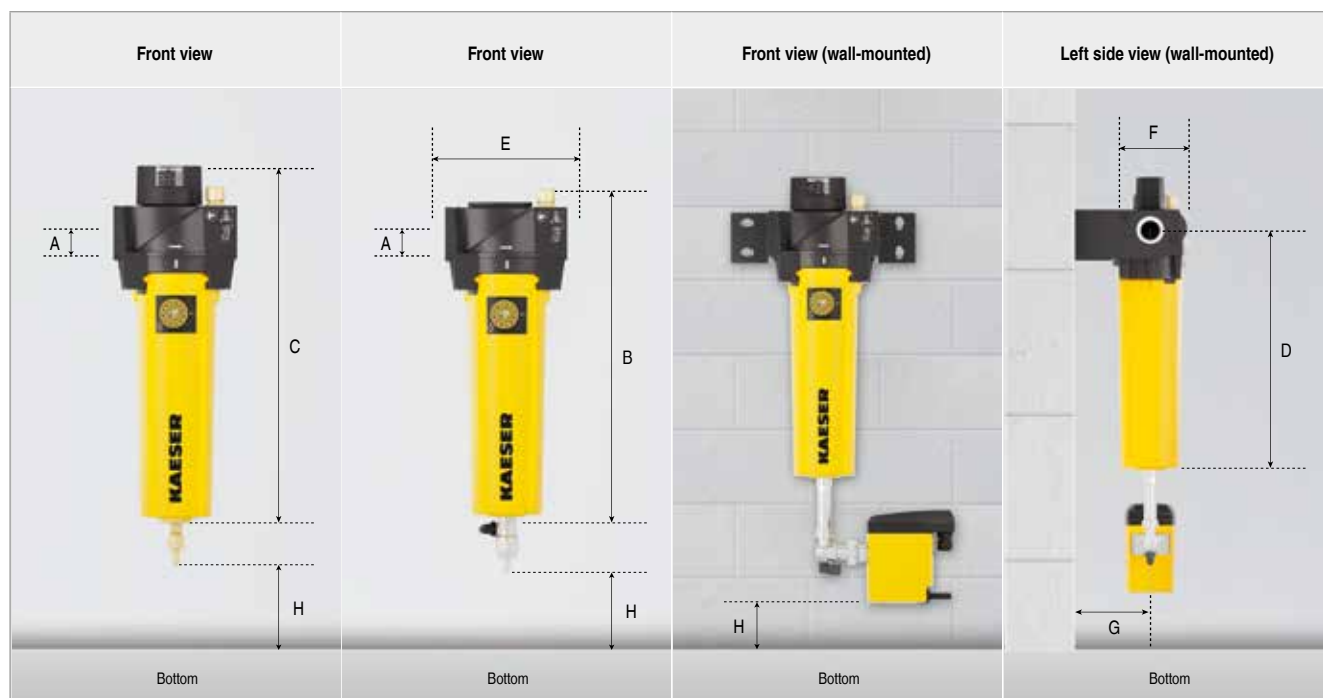

Technical specifications

For models F6 to F320 and filter grades KB/KE/KA/KD

Model	Flow rate ¹⁾ m ³ /min	Gauge pressure bar	Ambient temperature °C	Compressed air inlet temperature °C	Maximum weight kg	Electrical supply ECO-DRAIN
F6	0.60	2 to 16	+3 to +50	+3 to +66	3.6	95...240 VAC ±10% (50...60 Hz) / 100...125 VDC ±10%
F9	0.90				3.7	
F16	1.60	2 to 16	+3 to +50	+3 to +66	4.2	
F22	2.20				4.4	
F26	2.60				4.5	
F46	4.61	2 to 16	+3 to +50	+3 to +66	8.4	
F83	8.25				9.3	
F110	11.00				10.9	
F142	14.20				11.1	
F184	18.40	2 to 16	+3 to +50	+3 to +66	16.9	
F250	25.00				18.6	
F320	32.00				20.6	

¹⁾ Performance data at 7 bar gauge pressure relative to 1 bar ambient pressure (absolute) and +20 °C. The flow rate will change for deviating operating conditions.

Degrees of filtration

Degree of filtration	KB Coalescence filter Basic	KE Coalescence filter Extra	KD Particulate filter Dust	KA Activated carbon filter Adsorption	KBE Extra Combination	KEA Carbon Combination
Initial differential pressure at saturation	< 140 mbar	< 200 mbar	< 30 mbar (New, dry)	< 40 mbar (New, dry)	< 200 mbar	< 240 mbar
Aerosol content at inlet	10 mg/m ³	10 mg/m ³	–	–	10 mg/m ³	10 mg/m ³
Residual aerosol content at outlet as per ISO 12500-1 ¹⁾	< 0.1 mg/m ³	< 0.01 mg/m ³	–	–	< 0.01 mg/m ³	0.003 mg/m ³ (Total oil content)
Filter medium	Deep-pleated with support structure and polyester drainage matting		Deep-pleated with support structure	High-efficiency carbon matting	–	–
Application	Filtration of solid and liquid aerosols and solid particles	Same application as KB, but for higher compressed air quality Alternatively: Microparticle filter to KD degree of filtration	Exclusively for filtration of solid particles	Exclusively for removal of oil vapours	Combination of KB and KE; application as KE, but for higher compressed air quality	Combination of KE and KA, filtration of aerosols, solid particles and oil vapours

¹⁾ as per ISO 12500-1:06-2007

Calculating flow rate

Correction factors for deviating operating conditions (flow rates in m³/min x k...)

Deviating gauge working pressure p at filter inlet

p bar _(g)	2	3	4	5	6	7	8	9	10	11	12	13	14	15	16
k _p	0.38	0.50	0.63	0.75	0.88	1.00	1.06	1.12	1.17	1.22	1.27	1.32	1.37	1.41	1.46

Example:	Selected compressed air filter: F 83 with 8.25 m³/min (V_{Reference})
Gauge pressure: 10 bar(g) (See table)	k _p = 1.17
Max. possible flow rate under operating conditions	
V _{max} Operation = V _{Reference} x k _p	
V _{max} Operation = 8.25 m ³ /min x 1.17 = 9.65 m ³ /min	